

EDWARD TULANE

CURVED WALL - SIDE TOP FRAMES

DWG DESCRIPTION:
7'-0" TALL WALL FRAMED WITH 1X1 16 GAUGE STEEL TUBE.

DIRECTOR: JANET STANFORD
DESIGNER: SAMINA VIETH
TD: ELISE MASUR
DATE: 8/4/16 REV #: N/A

130

DWG BY EVM

SCALE 1" = 1'-0"

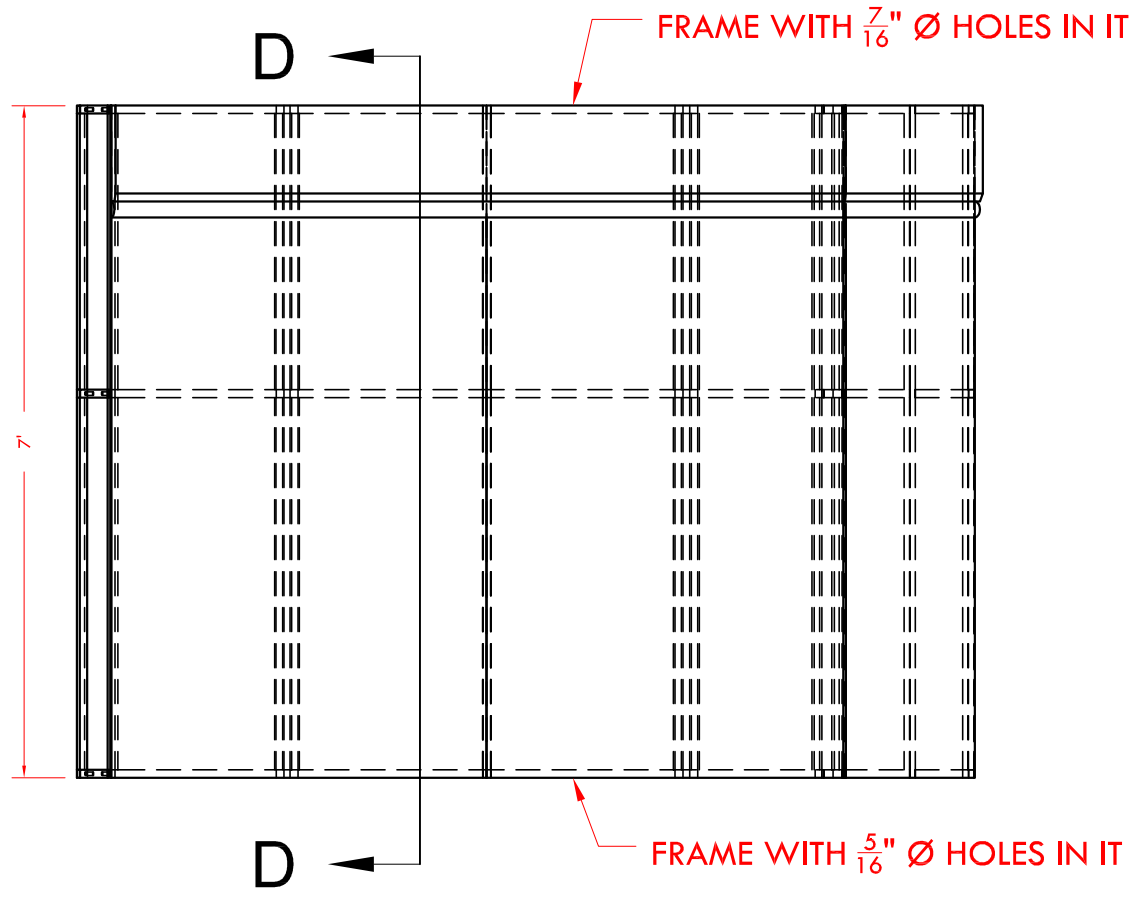
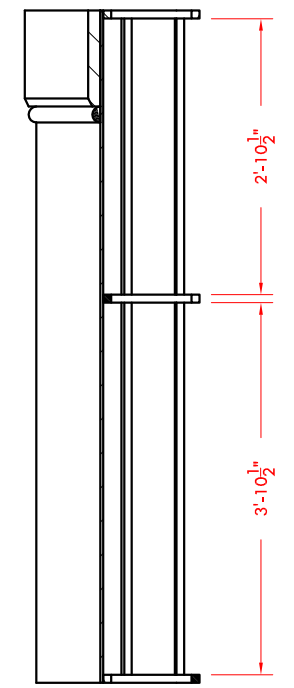
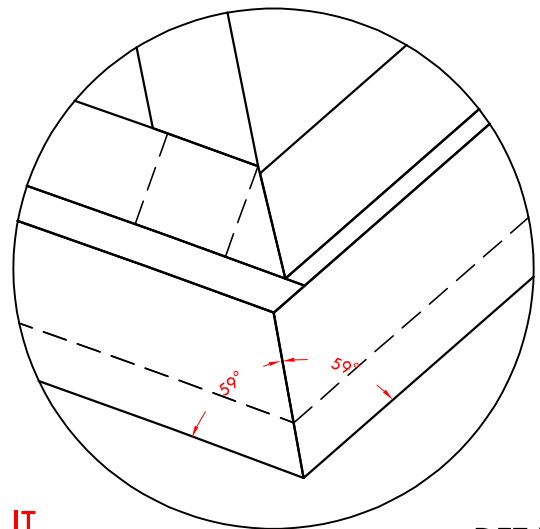
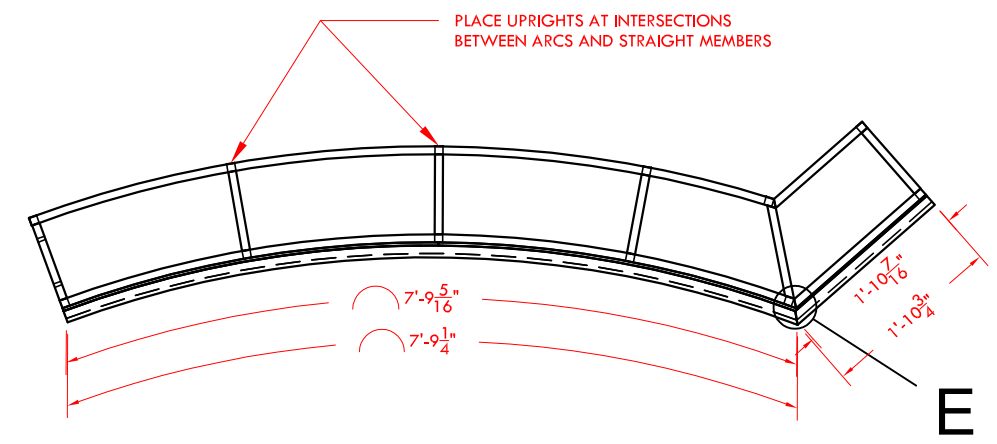
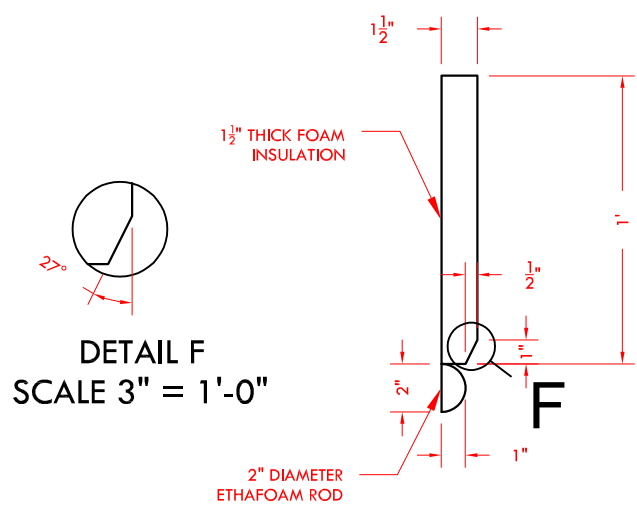

- NOTES:**
- MAKE 2 (REVERSE AND REPEAT)
 - WELD ALL UPRIGHTS IN PLACE
 - GRIND ALL SURFACE WELDS
 - ATTACH BENDY PLY AND LAUAN WITH TECH SCREWS
 - ** SEE ELISE FOR INFORMATION ABOUT ADDITIONAL BRACING AFTER WALL IS ASSEMBLED **