

5 FRONT ISO
Scale: NTS

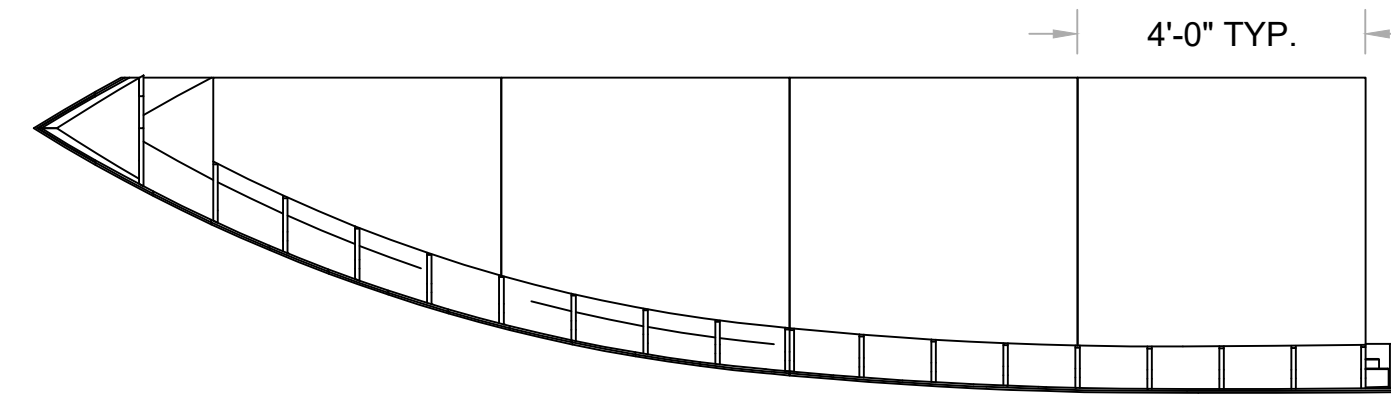

1 TOP
Scale: 3/8" = 1'-0"

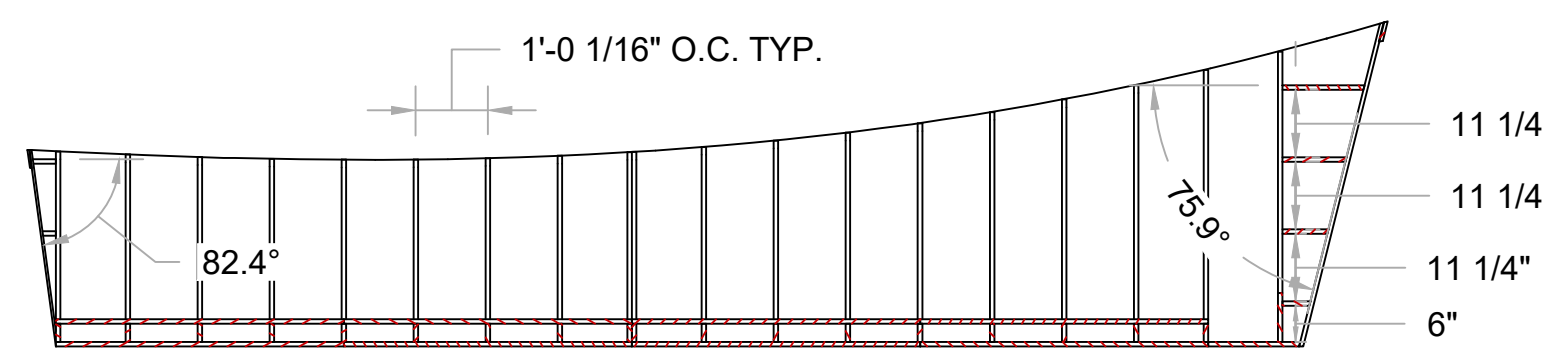

4 SECTION B-B
SCALE 3/8" = 1'-0"

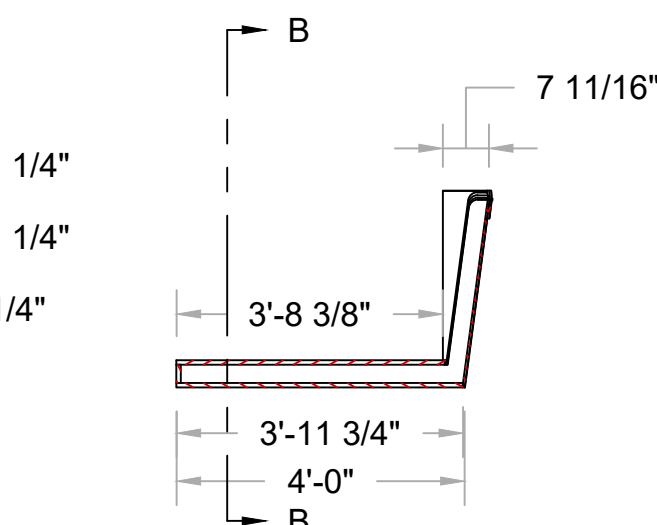

3 SECTION A-A
SCALE 3/8" = 1'-0"

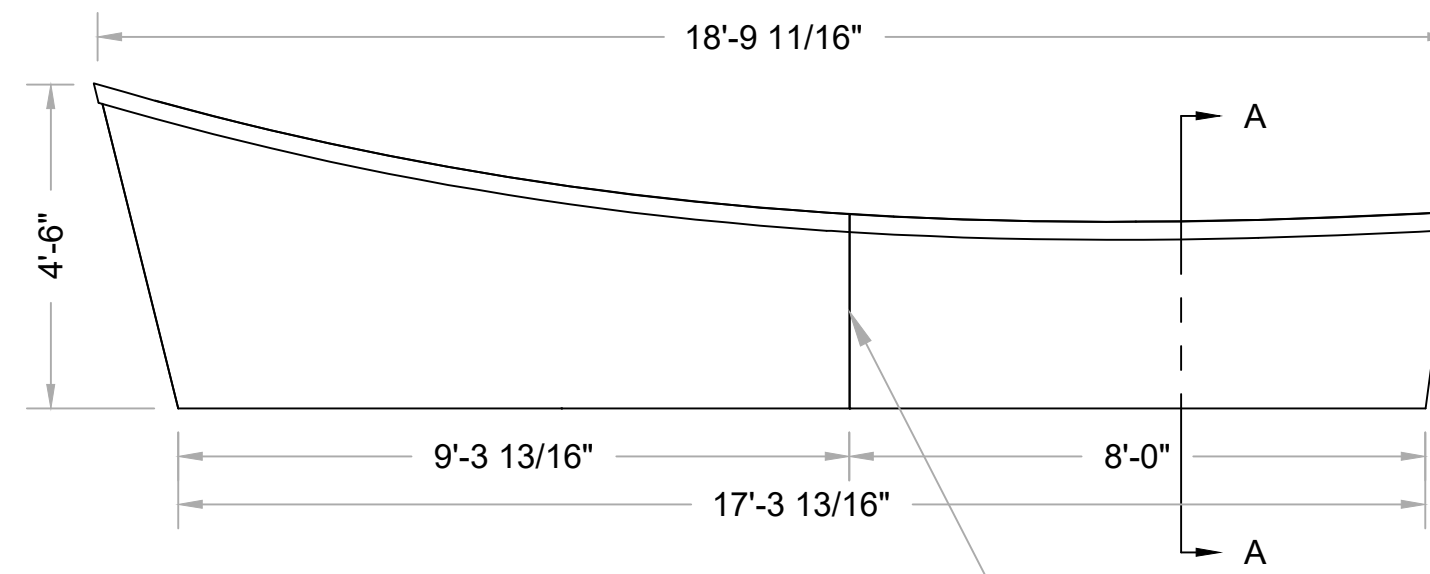

2 FRONT
Scale: 3/8" = 1'-0"

Boat breaks into two pieces at this seam

Note:
- Cut and assemble 3/4" plywood ribs and associated decking first
- All 3/8" bendy ply should be laid out and cut to fit frame

CNC'D RIBS ARE ALL UNIQUE; LABELING LETTERS SHOULD BE ETCHED INTO THEM WHEN THEY ARE CUT

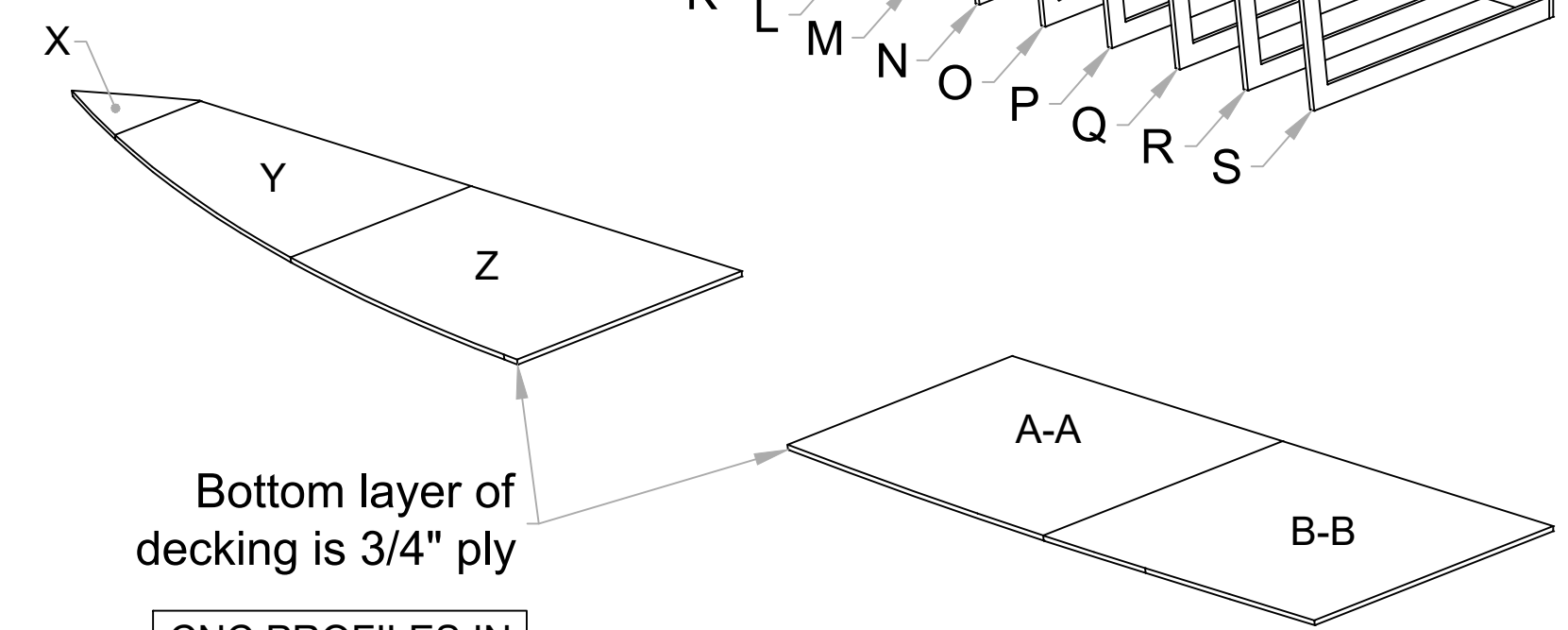
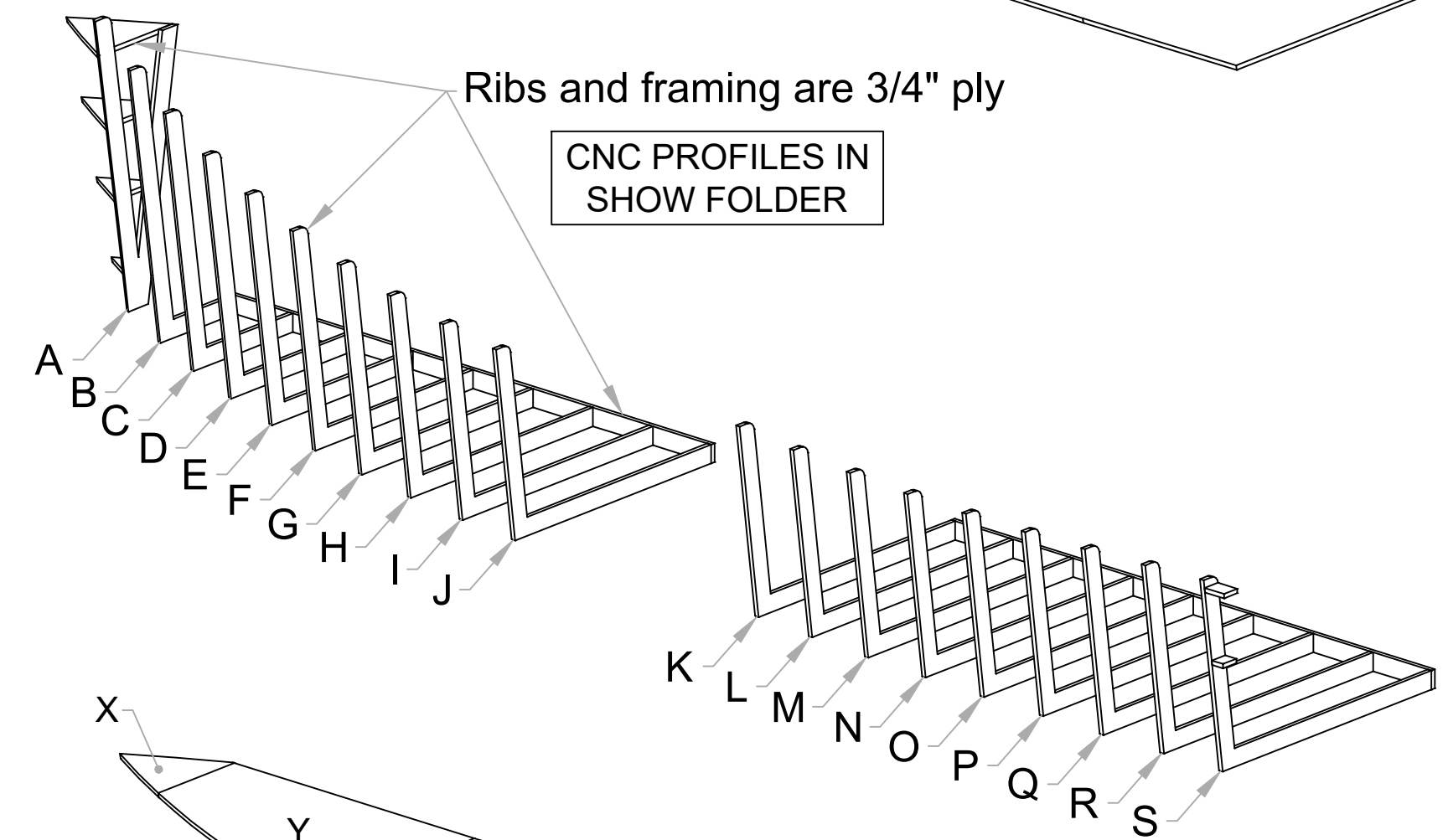
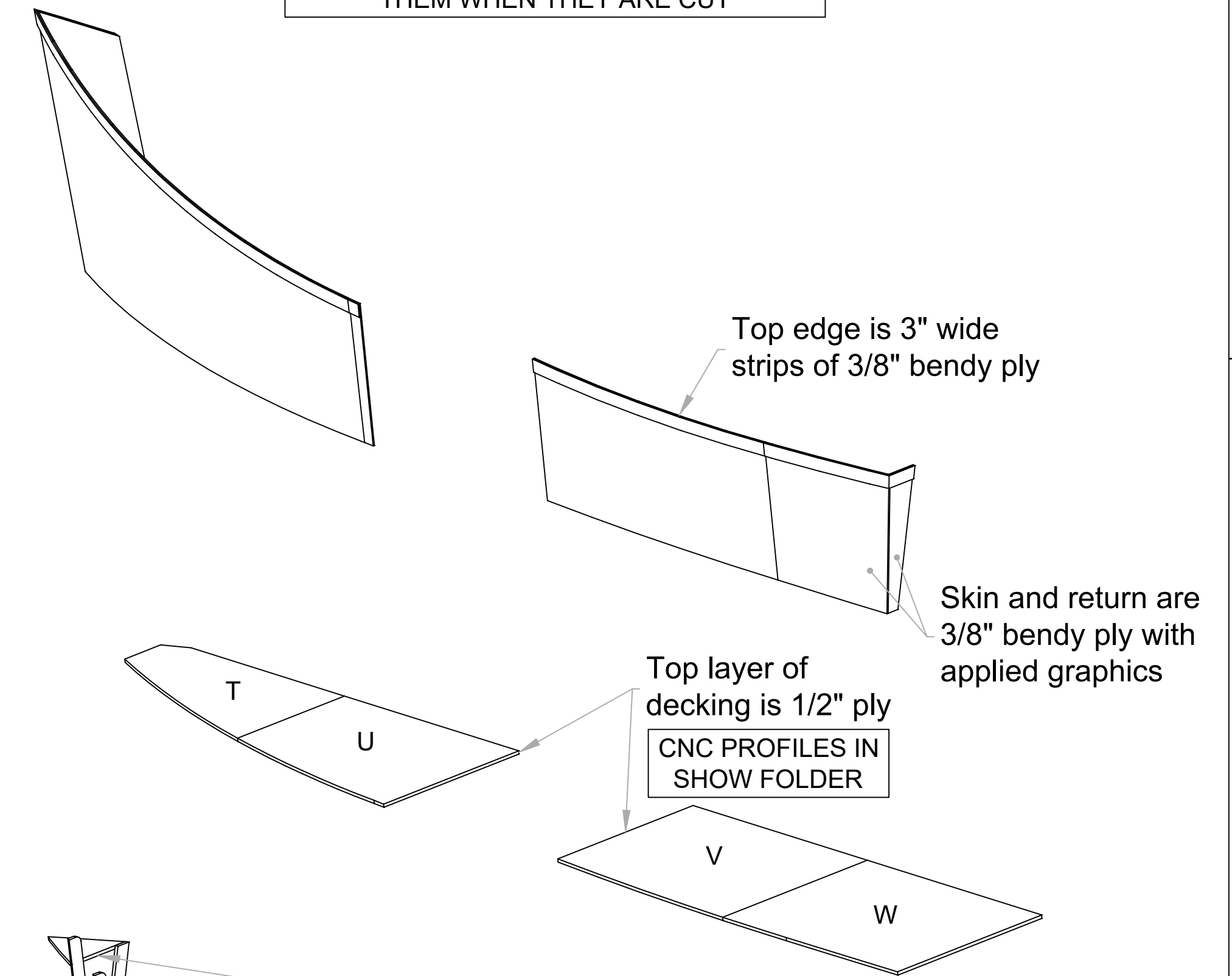

7 SEPARATED ISO
Scale: NTS