

1
103 2 GENTS BALCONY WITHOUT BASE MOLDING 1/2" = 1'-0"
SECTION VIEW OF BALCONY
MOLDING NOT INCLUDED FOR CLARITY
GLUE AND POCKET SCREW ALL PLYWOOD SWEEPS

2
103 2 GENTS BALCONY - FRAME AND DIAGONALS 1/2" = 1'-0"
FRAME IS 1X2 STEEL TUBE
WELD ALL JOINTS
GRIND DOWN WELDS ON TOP AND SIDES
USE 3/8" X 5" BOLTS TO CONNECT 4X4s TO FRAME

3
103 2 GENTS BALCONY - ISOMETRIC VIEW 1/2" = 1'-0"

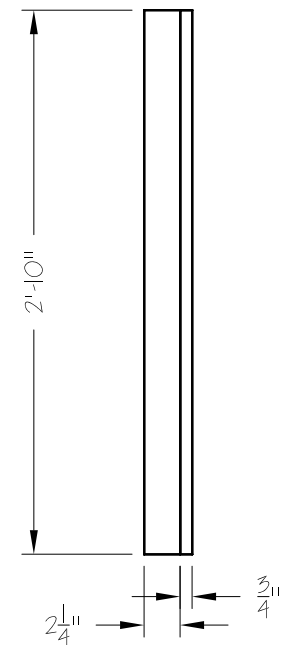
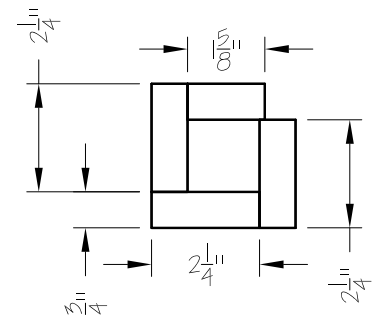

4
103 UPSTAGE UPRIGHTS - TOP VIEW 3/4" = 1'-0"
RIP TO SIZE FROM 1X MATERIAL
BUILD TWO (2); REVERSE AND REPEAT

5
103 UPSTAGE UPRIGHTS - FRONT VIEW 1/2" = 1'-0"
RIP TO SIZE FROM 1X MATERIAL
BUILD TWO (2); REVERSE AND REPEAT

Director: JEREMY WILLIAMS

Scenic Designer: HEATHER ROBERSON

Technical Director: PHIL BRULOTTE

Assistant Technical Director: ELISE MASUR

Scale: AS SHOWN

TWO GENTLEMEN OF VERONA

BALCONY

Plate Number:

103