

**NOTE:**  
 - When locating holes for bolts in rigging hardware, use holes cut into the 3/4" MDF skin as part of CNC profile

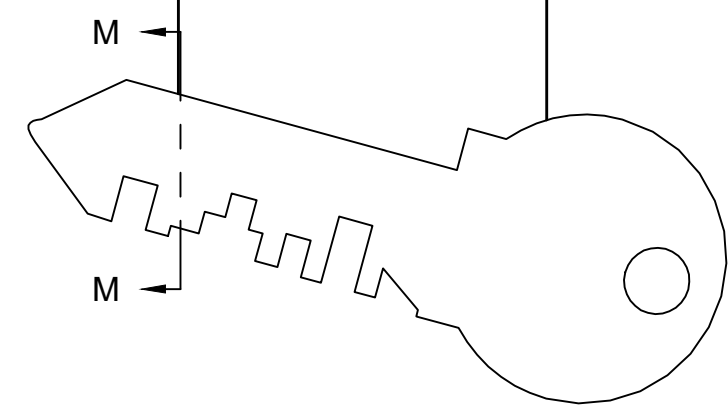

CNC PROFILE IS  
 IN SHOW FOLDER

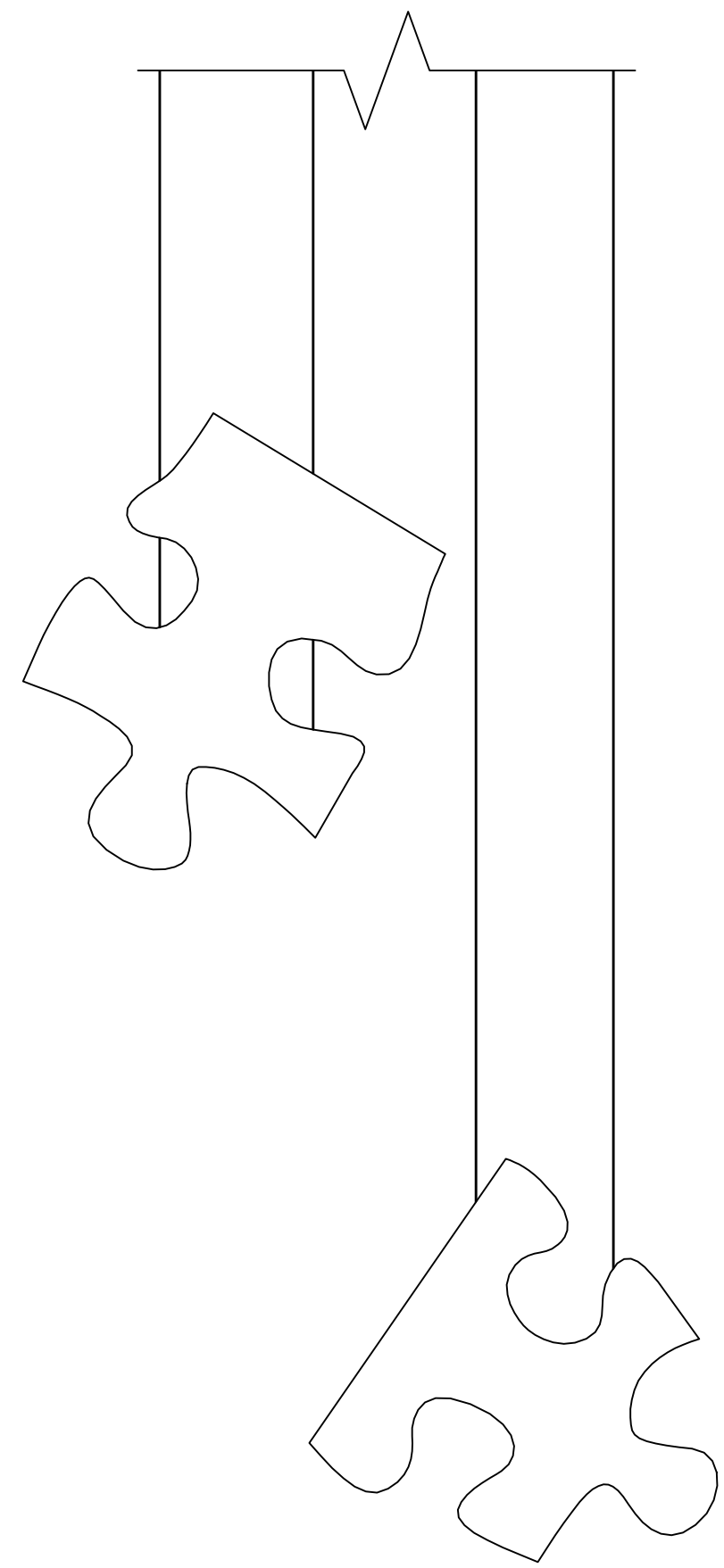
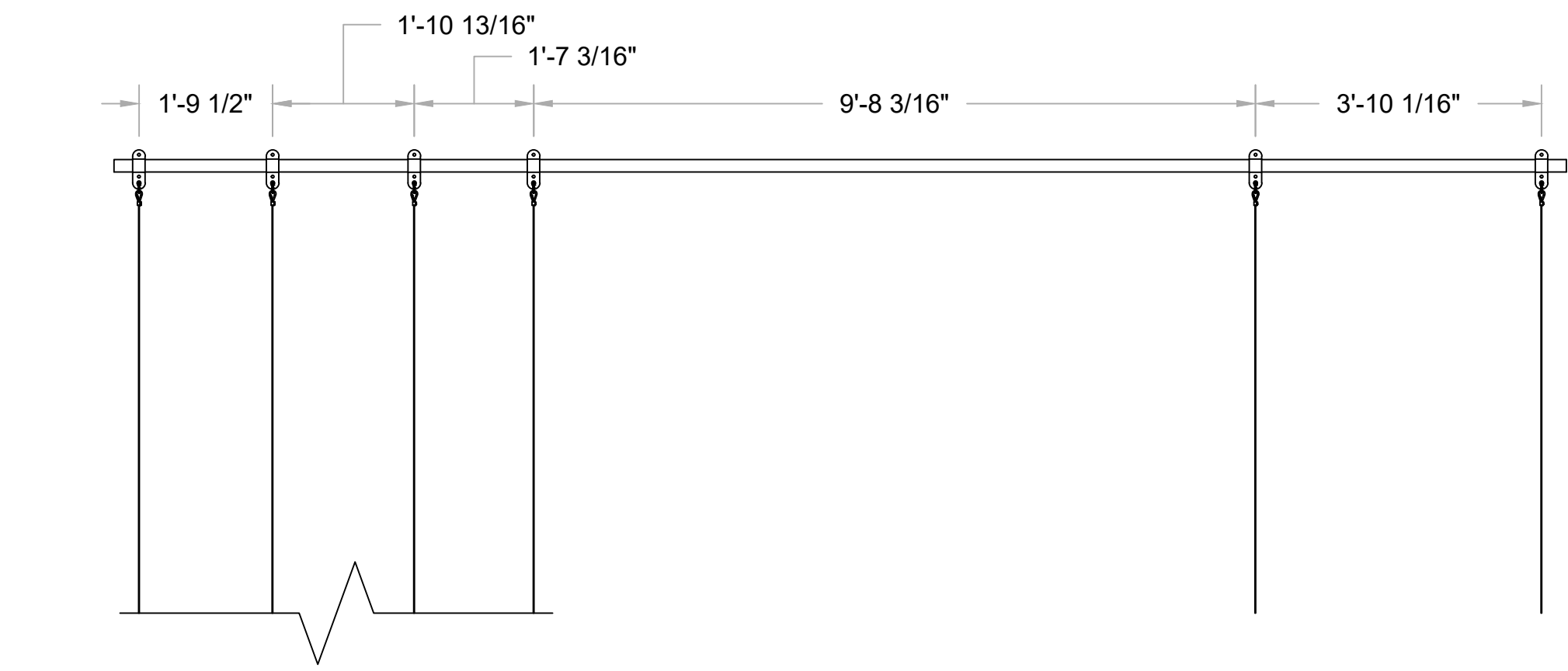
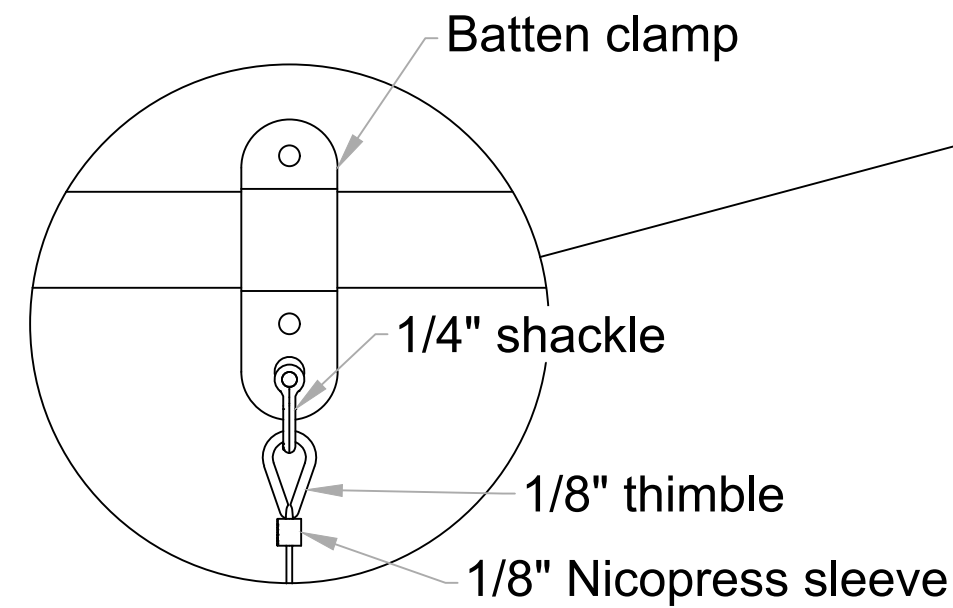

DETAIL O  
 SCALE 3" = 1'-0"

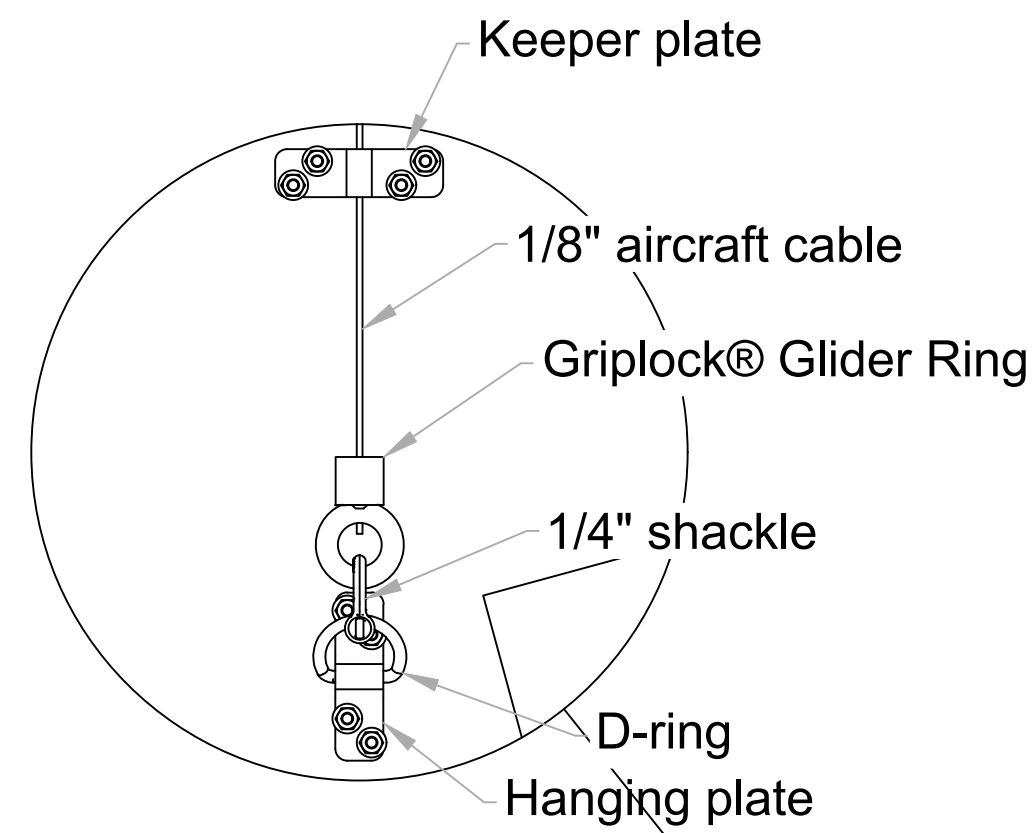

DETAIL P  
 SCALE 3" = 1'-0"

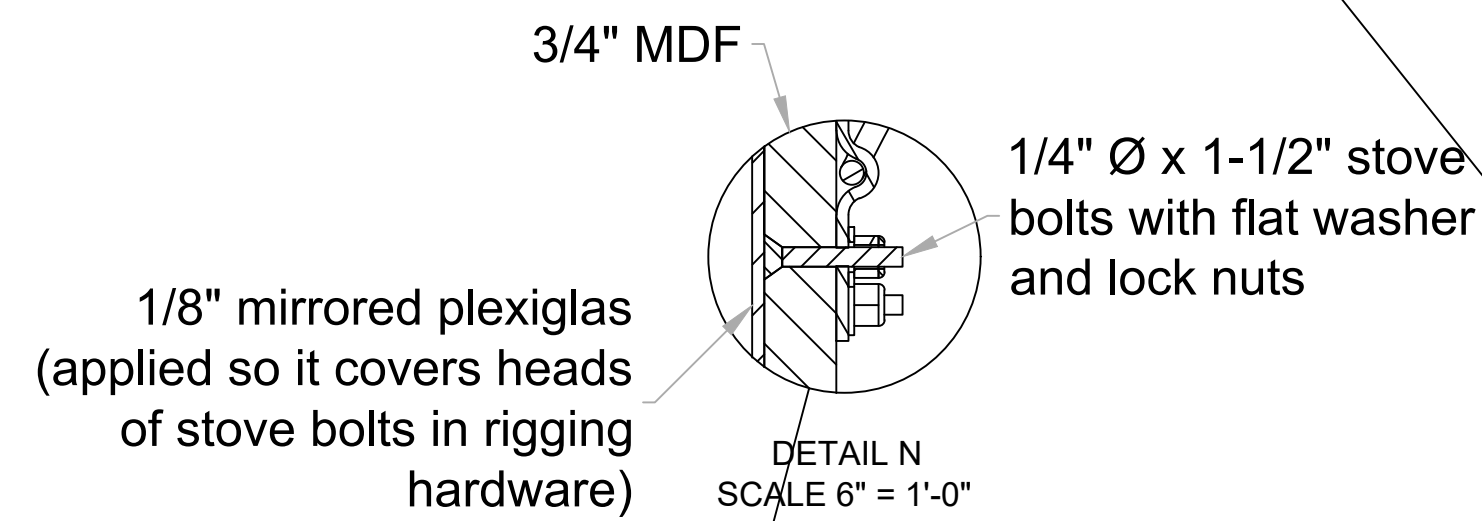

DETAIL N  
 SCALE 6" = 1'-0"

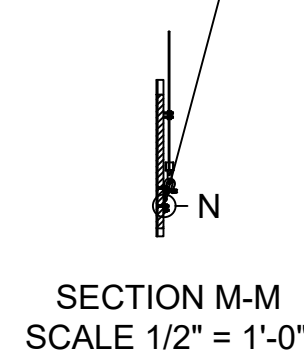

SECTION M-M  
 SCALE 1/2" = 1'-0"

